

**T.C.
MİLLÎ EĞİTİM BAKANLIĞI**

DENİZCİLİK

**STANDART DENİZCİLİK HABERLEŞME
CÜMLELERİ (SMCP)
840UH0082**

ANKARA, 2012

- Bu modül, mesleki ve teknik eğitim okul/kurumlarında uygulanan Çerçeve Öğretim Programlarında yer alan yeterlikleri kazandırmaya yönelik olarak öğrencilere rehberlik etmek amacıyla hazırlanmış bireysel öğrenme materyalidir.
- Millî Eğitim Bakanlığınca ücretsiz olarak verilmiştir.
- PARA İLE SATILMAZ.

CONTENTS

AÇIKLAMALAR	ii
INTRODUCTION.....	1
LEARNING ACTIVITY-1	3
1. INTRODUCTION OF SMCP	3
1.1. SMCP General	4
1.1.1. Procedure	4
1.1.2. Spelling.....	4
1.1.3. Message Markers	5
1.1.4. Responses	5
1.1.5. Distress, Urgency and Safety Signals	6
1.1.6. Standard Organizational Phrases.....	6
1.1.7. Corrections.....	7
1.1.8. Readiness	7
1.1.9. Repetition.....	7
1.1.10. Numbers.....	7
1.1.11. Positions.....	7
1.1.12. Bearings.....	8
1.1.13. Courses.....	8
1.1.14. Distances.....	8
1.1.15. Speed.....	8
1.1.16. Time	8
1.1.17. Geographical Names.....	8
1.1.18. Ambiguous words	8
1.2. Glossary	9
APPLICATION ACTIVITY.....	17
MEASURING AND EVALUATION	18
LEARNING ACTIVITY 2.....	20
2. USE OF SMCP.....	20
2.1. External Communication Phrases	20
2.1.1. Distress Communications	20
2.1.2. Urgency Communications	31
2.1.3. Safety Communications.....	32
2.1.4. Pilotage.....	37
2.1.5. Specials	40
2.1.6. Vessel Traffic Service (VTS) Standard Phrases	41
2.2. ON BOARD COMMUNICATION PHRASES	47
2.2.1. Operative Ship Handling	47
2.2.2. Safety on Board	53
2.2.3. Cargo and Cargo Handling.....	58
2.2.4. Passenger Care	62
APPLICATION ACTIVITY.....	66
MEASURING AND EVALUATION	68
GENERAL REVISION.....	69
ANSWER KEY	70
REFERENCES.....	73

AÇIKLAMALAR

KOD	840UH0082
ALAN	Denizcilik
DAL/MESLEK	Gemi Yönetimi
MODÜLÜN ADI	Standart Denizcilik Haberleşme Cümleleri (SMCP)
MODÜLÜN TANIMI	Öğrenciye, standart denizcilik haberleşme cümlelerini mesleğini yürütebilecek kadar, okuma, yazma, anlama ve kullanma yeterliğinde öğretilen derstir.
SÜRE	40/32
ÖN KOŞUL	Bu modülün ön koşulu yoktur.
YETERLİK	Her türlü durum için standart denizcilik haberleşme cümlelerini anlayarak, kullanabileceği derstir.
MODÜLÜN AMACI	Genel Amaç: Bu modül sonunda uygun ortam sağlandığında SMCP'yi tanıyıp, anlayıp her türlü denizcilik iletişimlerini İngilizce ifadelerle yapabileceksiniz. Amaçlar: 1. SMCP'nin haberleşme özelliklerini tanıyabilecektir. 2. SMCP'yi kullanabilecektir.
EĞİTİM ÖĞRETİM ORTAMLARI VE DONANIMLARI	Ortam: İngilizce Laboratuvarı Donanım: Projeksiyon, video kasetler, video oynatıcılar, İngilizce denizcilik sözlüğü
ÖLÇME VE DEĞERLENDİRME	Modül sonunda öğrenci SMCP'yi tanır, SMCP yazım kurallarını uygular, kalıpları haberleşmede kullanır, gemide haberleşme kalıplarını kullanır ve ilgili egzersizlerle öğrenmeyi pekiştirir.

INTRODUCTION

Dear Student;

The Maritime Safety Committee, at its sixty-eighth session (28 May to 6 June 1997), considered draft "Standard Marine Communication Phrases (SMCPs)" prepared by the Sub-Committee on Safety of Navigation and approved their dissemination by this circular.

The Committee invited Member Governments and international organizations concerned to conduct trials using the SMCPs attached hereto. Trials, preferably in non-English speaking areas, should be conducted on board ships, by maritime training institutes, search and rescue organizations, hydrographic offices, VTS personnel, pilots, port authorities and by any others involved in maritime communications who may be expected to use the SMCPs in the future.

Member Governments are requested to report the results of such experimental use of the SMCPs to the Organization as early as possible and preferably by March 1999 so as to be available for consideration in sufficient time before the forty-fifth session of the Sub-Committee on Safety of Navigation, which, in finalizing them, should take into account any comments thereon from the Sub-Committee on Standards of Training and Watch keeping.

LEARNING ACTIVITY-1

AIM

You will be given a general knowledge of SMCP.

SEARCH

- Visit a ship and try to find out a communication device.

1. INTRODUCTION OF SMCP (STANDART MARINE COMMUNICATION PHRASES)

These SMCP have been compiled to assist in the greater safety of navigation and the conduct of ship, to standardize the language used in communication for navigation at sea, in port-approaches, in waterways, harbors and on board vessels.

These phrases are not intended to supplant or contradict the International Regulations for Preventing Collisions at Sea, 1972 or special local rules or recommendations made by IMO concerning ships' routing. Neither are they intended to supersede the International Code of Signals nor to supplant normal radiotelephone practice as set out in the ITU Regulations.

These SMCP meet the requirements of the STCW Convention, 1978, as revised, and of the SOLAS Convention, 1974, as revised, regarding verbal communications moreover, the phrases cover the communication relevant safety aspects laid down in these Conventions. Knowledge, understanding and the competence to use the SMCP are required by the STCW Convention, 1978, as revised, for officers in charge of a navigational watch on vessels of 500 gross tonnages or more. Use of the communication phrases should be made as often as possible in preference to other wording of similar meaning, and they should be part of instruction in maritime education and training.

In this way they are intended to become an acceptable safety language, using the English language, for the verbal interchange of intelligence between individuals of all maritime nations on the many and varied occasions when precise meanings and translations are in doubt, increasingly evident under modern conditions at sea. For that purpose the

SMCP build on basic knowledge of the English language, and they have been drafted in a simplified version of maritime English intentionally reducing grammatical, lexical and idiomatic varieties to a tolerable minimum and standardized structures for the sake of the function of the SMCP, i.e. diminishing misunderstanding in safety related verbal communications. The typographical conventions used throughout most of this communication phrases are as follows:

- **Brackets** indicate that the part of the message enclosed within the brackets may be added where it is relevant, or they enclose a brief explanation of the preceding phrase;
- **Oblique stroke** indicates that the items on either side of the stroke are alternatives; and, **dots** indicate that the relevant information is to be filled in where the dots occur and (*italic letters*) indicate the kind of information requested.

1.1. SMCP General

Process and definitions of SMCP are as below.

1.1.1. Procedure

When it is necessary to indicate that the SMCP are to be used, the following message may be sent: "Please use Standard Marine Communication Phrases" "I will use Standard Marine Communication Phrases"

1.1.2. Spelling

When in external communication spelling is necessary, only the following spelling table should be used:

Letter	Code	Letter	Code
A	<u>Alfa</u>	N	<u>November</u>
B	<u>Bravo</u>	O	<u>Oscar</u>
C	<u>Charlie</u>	P	<u>Papa</u>
D	<u>Delta</u>	Q	<u>Quebec</u>
E	<u>Echo</u>	R	<u>Romeo</u>
F	<u>Foxtrot</u>	S	<u>Sierra</u>
G	<u>Golf</u>	T	<u>Tango</u>
H	<u>Hotel</u>	U	<u>Uniform</u>
I	<u>India</u>	V	<u>Victor</u>
J	<u>Juliet</u>	W	<u>Whisky</u>
K	<u>Kilo</u>	X	<u>X-ray</u>
L	<u>Lima</u>	Y	<u>Yankee</u>
M	<u>Mike</u>	Z	<u>Zulu</u>

Table 1.1 Spelling Table of Letter

Figure	Code word
0	Nadazero
1	Unaone
2	Bissotwo
3	Terrathree
4	Kartefour
5	Pantafive
6	Soxisix
7	Setteseven
8	Oktoeight
9	Novenine
Full stop	Stop
Decimal point	Decimal

Table 1.2. Spelling Table of Numbers

1.1.3. Message Markers

In shore-to-ship and ship-to-shore communication or radio communication in general, the following eight Message Markers may be used.

- (i) Instruction
- (ii) Advice
- (iii) Warning
- (iv) Information
- (v) Question
- (vi) Answer
- (vii) Request
- (viii) Intention

1.1.4. Responses

-When the answer to a question is in the affirmative, say:
"Yes ..." followed by the appropriate phrase in full.

-When the answer to a question is in the negative, say:
"No ..." - followed by the appropriate phrase in full.

-When the information requested is not immediately available, say:
"Stand by" - followed by the time interval within which the information will be available.

-When the information requested cannot be obtained, say: "No information."

-When an INSTRUCTION (e.g. by a VTS-Station, Naval vessel or other fully authorized personnel) or an ADVICE is given, respond if in the affirmative:

"I will/can ..." - followed by the instruction or advice in full; and, if in the negative, respond: "I will not/cannot ..." - followed by the instruction or advice in full.

-Example: "ADVICE. Do not overtake vessel ahead of you." Respond: "I will not overtake vessel ahead of me." The responses to orders of special importance, however, are given in wording in the phrases concerned.

1.1.5. Distress, Urgency and Safety Signals

5.1	MAYDAY	is to be used to announce a distress message
5.2	PAN - PAN	is to be used to announce an urgency message
5.3	SÈCURITÈ	is to be used to announce a safety message

Table 1.3. Signals

1.1.6. Standard Organizational Phrases

- "How do you read?"

"I read you ..."

bad/one	with signal strength one	(i.e. barely perceptible)
poor/two	with signal strength two	(i.e. weak)
fair/three	with signal strength three	(i.e. fairly good)
good/four	with signal strength four	(i.e. good)
excellent/five	with signal strength five	(i.e. very good)

Table 1.4. Phrases

-When it is advisable to remain on a VHF channel/frequency say:

"Stand by on VHF channel ... /frequency ..."

-When it is accepted to remain on the VHF channel/frequency indicated, say:

"Standing by on VHF channel ... "/frequency ..."

-When it is advisable to change to another VHF channel/frequency, say:

"Advise (you) change to VHF channel ... /frequency ...", "Advise (you) try VHF channel ... /frequency."

-When the changing of a VHF channel/frequency is accepted, say:

"Changing to VHF channel ... /frequency ..."

1.1.7. Corrections

-When a mistake is made in a message, say:
"Mistake ..." - followed by the word:
"Correction ..." plus the corrected part of the message.

-Example: "My present speed 14 knots - mistake.
Correction, my present speed 12, one-two, knots."

1.1.8. Readiness

- "I am / I am not ready to receive your message".

1.1.9. Repetition

-If any part of the message are considered sufficiently important to need safeguarding, say: "Repeat ..." - followed by the corresponding part of the message.

-Example: "My draft 12.6 repeat one-two decimal 6 meters." "Do not overtake - repeat - do not overtake."

-When a message is not properly heard, say: "Say again (please)."

1.1.10. Numbers

Numbers are to be spoken in separate digits: "One-five-zero" for 150
"Two decimal five" for 2.5

Note: Attention! When rudder angles e.g. in wheel orders are given, say: "Fifteen" for 15 or "Twenty" for 20 etc.

1.1.11. Positions

When latitude and longitude are used, these shall be expressed in degrees and minutes (and decimals of a minute if necessary), north or south of the Equator and east or west of Greenwich.

Example: "WARNING. Dangerous wreck in position 15 degrees 34 minutes north
61 degrees 29 minutes west."

When the position is related to a mark, the mark shall be a well-defined charted object. The bearing shall be in the 360 degrees notation from true north and shall be that of the position FROM the mark.

"Your position bearing 137 degrees from Barr Head lighthouse distance 2.4 nautical miles."

1.1.12. Bearings

The bearing of the mark or vessel concerned is the bearing in the 360 degree notation from north (true north unless otherwise stated), except in the case of relative bearings. Bearings may be either FROM the mark or FROM the vessel. Examples: "Pilot boat bearing 215 degrees from you."

1.1.12.1. Relative Bearings

Relative bearings can be expressed in degrees relative to the vessel's head or bow. More frequently this is in relation to the port or starboard bow.

Example: "Buoy 030 degrees on your port bow."(Relative D/F bearings are more commonly expressed in the 360 degree notation.)

1.1.13. Courses

Always to be expressed in 360 degree notation from north (true north unless otherwise stated). Whether this is to TO or FROM a mark can be stated.

1.1.14. Distances

Preferably to be expressed in nautical miles or cables (tenths of a mile) otherwise in kilometers or meters, the unit always to be stated.

1.1.15. Speed

To be expressed in knots without further notation meaning speed through the water; or, "ground speed" meaning speed over the ground.

1.1.16. Time

Times should be expressed in the 24 hour notation indicating whether UTC, zone time or local time is being used.

1.1.17. Geographical Names

Place names used should be those on the chart or Sailing Directions in use. Should these not be understood, latitude and longitude should be given.

1.1.18. Ambiguous words

Some words in English have meanings depending on the context in which they appear. Misunderstandings frequently occur, especially in VTS communications, and have produced accidents. Such words are:

- The Conditionals "May", "Might", "Should" and "Could":

May

Do not say: "May I enter fairway?"

Say: "QUESTION. Is it permitted to enter fairway?"

Do not say: "You may enter fairway."

Say: "ANSWER. It is permitted to enter fairway."

Might

Do not say: "I might enter fairway."

Say: "INTENTION. I will enter fairway."

Should

Do not say: "You should anchor in anchorage B 3."

Say: "ADVICE. Anchor in anchorage B 3."

Could

Do not say: "You could be running into danger."

Say: "WARNING. You are running into danger."

The word "Can"

The word "Can" either describes the possibility or the capability of doing something. In the SMCP the situations where phrases using the word "Can" appear make it clear whether a possibility is referred to. In an ambiguous context, however, say, for example:

"QUESTION is it permitted to use shallow draft fairway at this time?"

Do not say: "Can I use shallow draft fairway at this time?", if you ask for permission. (The same applies to the word "May")

1.2. Glossary

Abandon vessel: To evacuate a vessel from crew and passengers following a distress

Adrift: Floating, not controlled, without a clearly determinable direction

Assembly station: Place on deck, in mess rooms, etc., assigned to crew and passengers where they have to meet according to the muster list when the corresponding alarm is released or announcement made.

Backing (of wind): When a wind blows round anticlockwise (opposite of veering)

Blast: A sound signal made with the whistle of the vessel

Boarding arrangements: All gear, such as pilot ladder, accommodation ladder, hoist, etc., necessary for a safe transfer of the pilot

Boarding speed: The speed of a vessel adjusted to that of a pilot boat at which the pilot can safely embark.

Briefing: concise explanatory information to crew and passengers

Capsizing: Turning of a vessel upside down while on water

Cardinal buoy: A seamark, i.e. a buoy, indicating the north, east, south or west from a fixed point, e.g. a wreck

Casualty: Case of death or serious injury to a person in an accident or shipping disaster, also said of a distressed vessel

Close coupled towing: A method of towing vessels through polar ice by means of icebreaking tugs with a special stern notch suited to receive and hold the bow of the vessel
To be towed

Compatibility (of goods): states whether different goods can be stowed together in one hold

Convoy: A group of vessels which sail together, e.g. through a canal or ice

COW: Crude oil washing: A system of cleaning the tanks by washing them with the cargo of crude oil while it is being discharged

CPA: Closest point of approach

Disabled: A vessel damaged or impaired in such a manner as to be incapable of proceeding its voyage.

Disembark (to): To go from board a vessel

Distress alert (GMDSS): A radio signal from a distressed vessel automatically directed to a RCC giving position, identification, course and speed of the vessel as well as the nature of distress

Dragging (of anchor): Moving of an anchor over the sea bottom involuntarily because it is no longer preventing the movement of the vessel

Dredging (of anchor): Moving of an anchor over the sea bottom to control the movement of the vessel

Drifting: Floating, caused by winds and current with a determinable direction

Drop back (to): To increase the distance to the vessel ahead by reducing one's own speed

Embark (to): To go aboard a vessel

ETD: Estimated time of departure

Fairway: Navigable part of a waterway Fairway speed Mandatory speed in a fairway

Foul (of anchor): Anchor has its own cable twisted around it or has fouled an obstruction

Foul (of propeller): A line, wire, net, etc., is wound round the propeller

Full speed: Highest possible speed of a vessel

GMDSS: Global maritime distress and safety system

Inoperative: Not functioning

Leeway: Lateral movement of the vessel to leeward of its course

Let go (to): To set free, let loose, or cast off (of anchors, lines, etc.)

Lifeboat station: Place assigned to crew and passengers where they have to meet before they will be ordered to enter the lifeboats.

List: Inclination of the vessel to port side or starboard side

Off station (of buoys): Not at the position charted

Oil clearance: An operation to remove oil from the water surface

Operational: Ready for immediate use

Ordnance exercise: Naval firing practice

Restricted area: A deck, space, area, etc., not permitted to be entered for safety reasons

Retreat signal: Sound, visual or other signal to a team ordering it to return to its base

Rig move: The movement of an oil rig, drilling platform, etc., from one position to another

Roll call: The act of checking who of the passengers and crew members are present, e.g.

At assembly stations, by reading aloud a list of their names

Safe speed: That speed of a vessel allowing the maximum possible time for effective action

to be taken to avoid a collision and to be stopped within an appropriate distance

Safety load: The maximum permissible load of a deck, etc.

Safe working pressure: The maximum permissible pressure in cargo hoses

SAR: Search and rescue

Scene: The area where the event, e.g. an accident has happened

Slings: Ropes, nets, and any other means for handling general cargoes

Speed of advance: The speed at which a storm center moves

Spill (to): To accidentally escape, e.g. oil, etc., from a vessel, container, etc., into the sea

Spill control gear: Special equipment for fighting accidental oil spills at early stages

Standing orders: Orders of the Master to the officers of the watch which s/he must comply with

Stand on (to): To maintain course and speed

Station: The allotted place or the duties of each person on board

Take off (to). To start with the helicopter from a vessel's deck

Target: The echo generated e.g. by a vessel on a radar screen

Transshipment (of cargo) here: The transfer of goods from one vessel to another outside harbors

Transit: The passage of a vessel through a canal, fairway, etc.

Transit speed: Speed of a vessel required for the passage through a canal, fairway, etc.

Underway: A vessel which is not at anchor, or made fast to the shore, or aground

Unlit: When the light characteristics of a buoy or a lighthouse are inoperative

UTC: Universal time coordinated (ex GMT)

Variable (of winds): When a wind is permanently changing the direction from which it blows

Veering (of winds): When a wind blows round clockwise; opposite of backing

Vessel traffic service: A service, designed to improve safety, efficiency, and easiness of vessel traffic and to protect the environment

VTS-area: Area controlled by a VTS-Centre or VTS-Station

Windward: The general direction from which the wind blows; opposite of leeward

Wreck: A vessel which has been destroyed or sunk or abandoned at sea

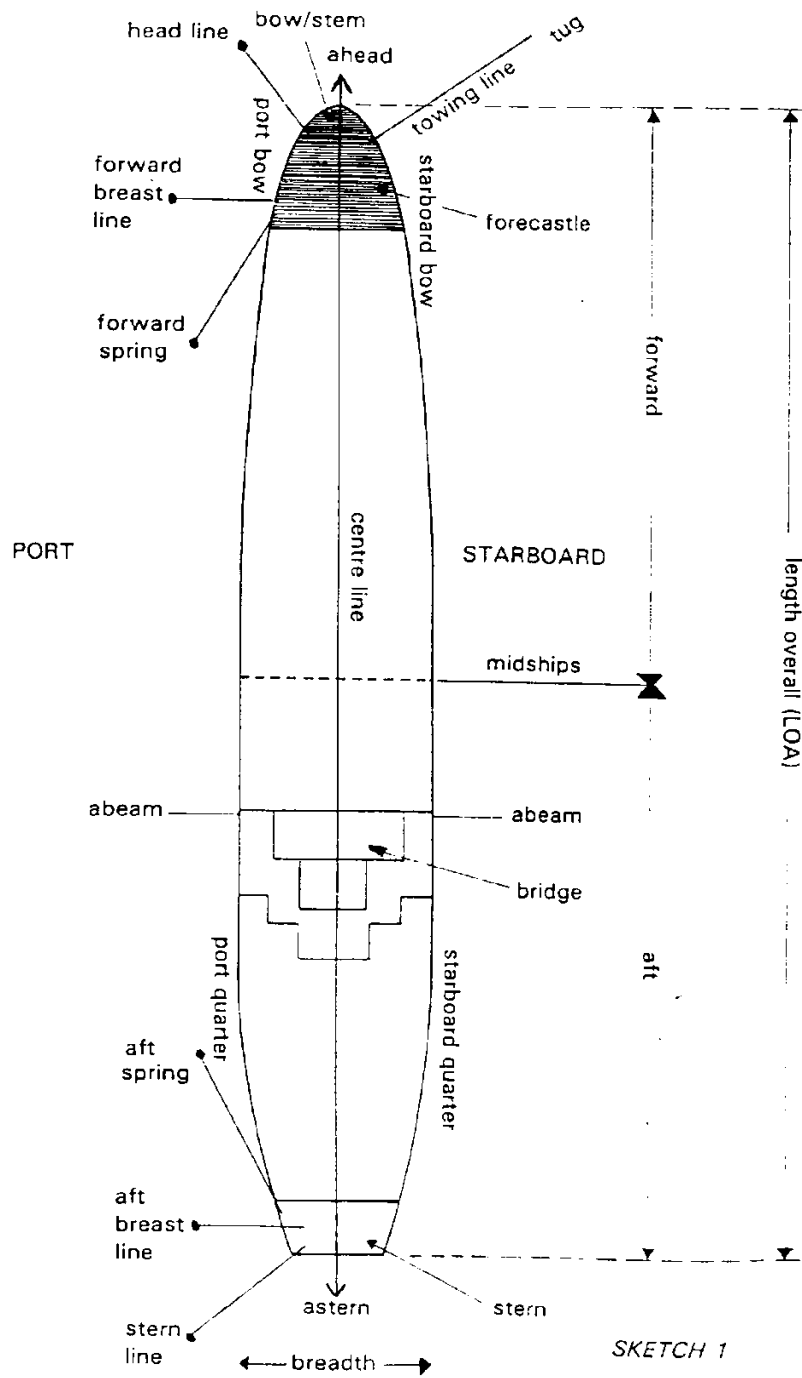

Picture 1.1. Directions and parts of ship

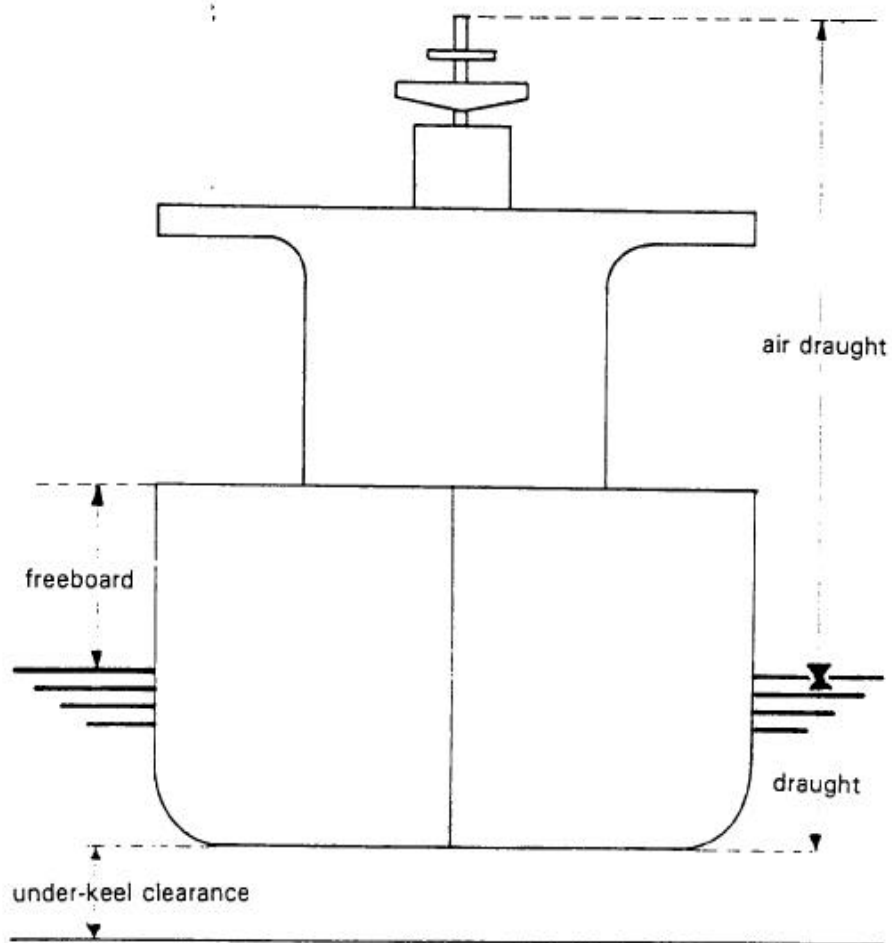

SKETCH 2

Picture 1.2. Ship's part for stability

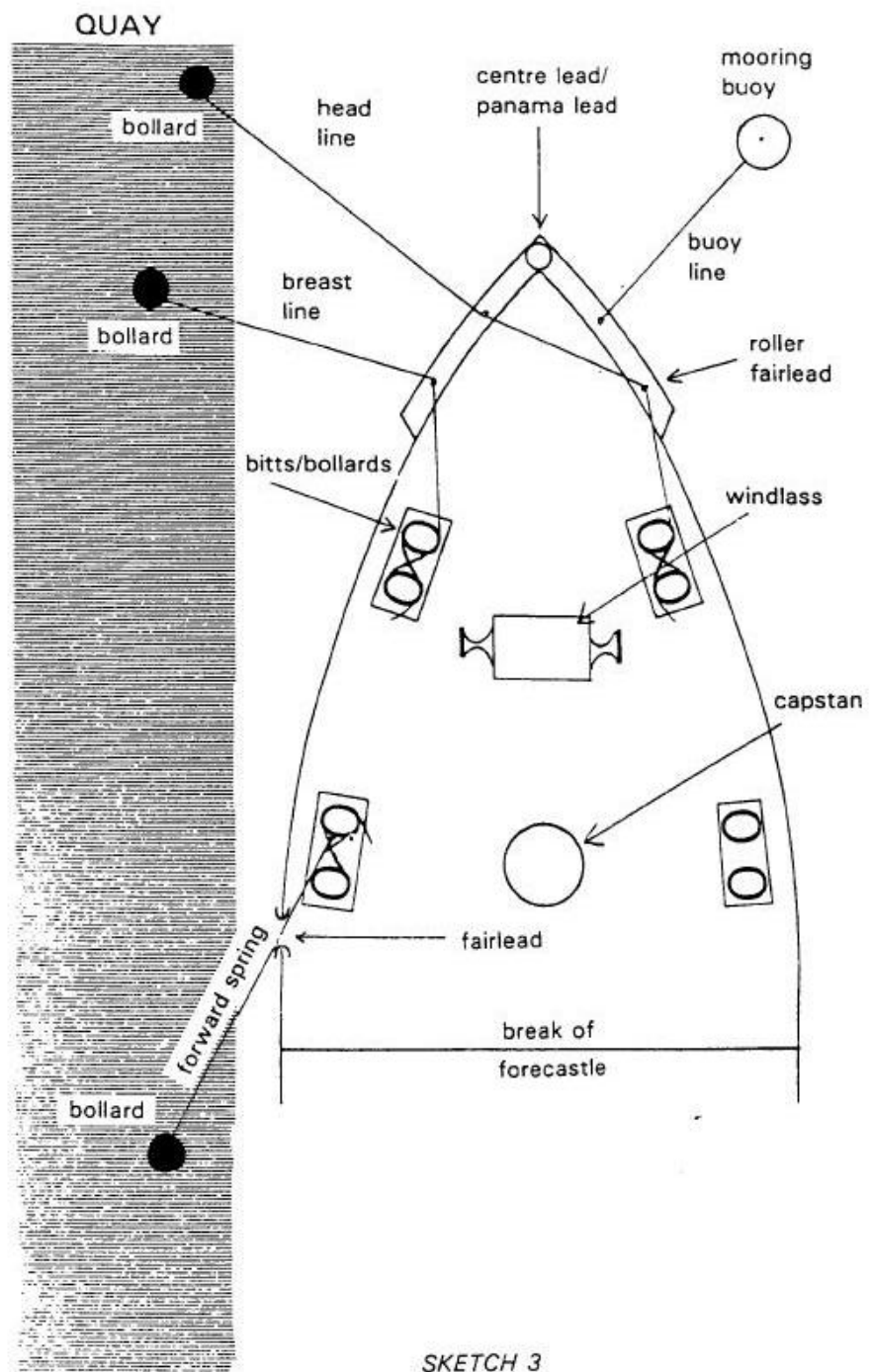

Picture 1.3. Ship's part for maneuvering

APPLICATION ACTIVITY

Steps Of Process	Suggestions
<ul style="list-style-type: none"> ➤ First of all, you should read marine phonetic alphabet and their meanings 2 or 3 times ➤ Then choose some letter from alphabet and guess the meaning ➤ Then you should draw ship with your pencil ➤ And you should write main parts and maneuvering parts of ship on your picture. ➤ Then make dialogs with your friends with using standard marine communication words and phrases. 	<ul style="list-style-type: none"> ➤ During application you should be careful for writing and pronouncing mistakes

CHECKLIST

If you have behaviors listed below, evaluate yourself putting (X) in “Yes” box for your earned skills within the scope of this activity otherwise put (X) in “No” box.

Evaluation Criteria	Yes	No
➤ Do you know SMCP’s usage purpose?	<input type="checkbox"/>	<input type="checkbox"/>
➤ Do you know how to spell letters?	<input type="checkbox"/>	<input type="checkbox"/>
➤ Do you know how to spell numbers?	<input type="checkbox"/>	<input type="checkbox"/>

EVALUATION

Please review your” No” answers in the form at the end of the evaluation. If you do not find yourself enough, repeat learning activity. If you give all your answers "Yes" to all questions, pass to the "Measuring and Evaluation".

MEASURING AND EVALUATION

1. Complete the sentences.

- a) SMCP has been compiled _____
- b) MAYDAY means _____
- c) PAN – PAN means _____
- d) SÈCURITÈ means _____
- e) Times should be expressed _____

2. Complete the charts.

Letter	Code	Letter	Code
A		N	
B		O	
C		P	
D		Q	
E		R	
F		S	
G		T	
H		U	
I		V	
J		W	
K		X	
L		Y	
M		Z	

Figure	Code word
0	
1	
2	
3	
4	
5	
6	
7	
8	
9	
Full stop	
Decimal point	

EVALUATION

Please compare the answers with the answer key. If you have wrong answers, you need to review the Learning Activity. If you give right answers to all questions, pass to the next learning activity.

LEARNING ACTIVITY 2

AIM

You will learn and express maritime phrases.

SEARCH

- Visit a ship and observe how the captain communicates with harbor and other ships.

2. USE OF SMCP

Importance of SMCP and all marine phrases in all conditions are told as below.

2.1. External Communication Phrases

The use of Standard Phrases in ships' external communication does not in any way exempt from applying the relevant ITU - Radio Regulations and Procedures for Radio Telephony.

2.1.1. Distress Communications

Distress communications contain different situations .They are told as below.

2.1.1.1. Distress Messages and Their Types

- Fire, explosion

*Vessel on fire (after explosion) in position....

I am on fire in position....

*What is on fire?

Engine room on fire.

Hold(s) on fire.

(Deck) cargo on fire.

Superstructure on fire

Accommodation on fire.

... On fire.

*Are dangerous goods on fire?
Yes, oil/... on fire.
No, dangerous goods not on fire.

*Is danger of explosion?
Yes, danger of explosion.
No, no danger of explosion.

*What is damage?
No damage.
No power supply.
I am not under command.
I am making water.
I am sinking.

*Is fire under control?
Yes, fire under control.
No, fire not under control (fire spreading).

*Can you get fire under control?
Yes, I can get fire under control.
No, I cannot get fire under control.

*Is smoke toxic?
Yes, smoke toxic.
No, smoke not toxic.

*What kind of assistance do you require?
I require foam extinguishers.
I require CO₂ extinguishers.
I require fire pumps.
I require fire fighting assistance.
I require....
I do not require assistance.

*Report injured persons.
No person injured.
Number of injured persons/casualties:
I require medical assistance.

-Flooding

*I have leak below water line.
I am making water.

*Can you stop leak?
Yes, I can stop leak.
No, I cannot stop leak.

*Can you control flooding?
Yes, I can control flooding.
No, I cannot control flooding.

*What kind of assistance do you require?
I require pumps.
I require divers.
I require....

*I will send pumps.
I will send divers.
I will send....
I cannot send....
I have dangerous list.
I am in critical condition.

*How many compartments flooded?
... Compartments flooded.
Flooding under control.

*Can you proceed without assistance?
Yes, I can proceed without assistance.
No, I cannot proceed without assistance.
I require escort.

-Collision

*I have collided with MV....
I have collided with unknown vessel/object.
I have collided with ... (*name*) light vessel.
I have collided with seamark ... (*charted name*).
I have collided with iceberg.
I have collided with....

*What is damage?
I have minor/major damage above/below water line.
Propeller/rudder damaged.
I can only proceed at slow speed.
I am not under command.

*Can you repair damage?
Yes, I can repair damage.
No, I cannot repair damage.

*What kind of assistance do you require?
I require escort.
I require tugs.
I require....

-Grounding

*Are you aground?
Yes, aground in position.....
Yes, aground on rocky bottom.
Yes, aground on soft bottom.

*I went aground in position ... require assistance.
I went aground at high water.
I went aground at half water.
I went aground at low water.

*What part is aground?
A ground forward.
A ground amidships.
A ground aft.
A ground full length.

*What kind of assistance do you require?
I require pumps.
I require escort.
I require tugs.
I require....
I do not require assistance.
Uncharted rocks in position....
Risk of grounding at low water.

*Can you jettison cargo forward/aft to refloat?
Yes, I can jettison cargo forward/aft.
No, I cannot jettison cargo.
Attention! Do not jettison IMO-class cargo.

*When do you expect to refloat?
I expect to refloat at...
I expect to refloat when tide rises.
I expect to refloat when weather improves.
I expect to refloat when draft decreases.
I expect to refloat with tug assistance.

*Can you beach?
Yes, I can/will beach in position....
No, I cannot beach.

-List, danger of capsizing

*I have heavy list to port side/starboard side.
I have heavy list due to flooding.
I have heavy list due to shifting cargo.

*List increasing.
List decreasing.
I am in danger of capsizing.

*Can you transfer cargo/bunkers to stop listing?
Yes, I can transfer cargo/bunkers.
No, I cannot transfer cargo/bunkers.
I have transferred cargo/bunkers to stop listing

*Listing stopped after transferring.
Listing did not stop after transferring.

*Can you jettison cargo to stop listing?
Yes, I can jettison cargo.
No, I cannot jettison cargo.
I have jettisoned cargo to stop listing.

*Listing stopped after jettisoning.
Listing did not stop after jettisoning.

*Can you beach?
Yes, I can/will beach in position....
No, I cannot beach.

-Sinking

*I am sinking in position ... after collision.
I am sinking after grounding.
I am sinking after flooding.
I am sinking after explosion.
I am sinking after....

*I require assistance.
I proceed to your assistance.
I expect to reach you within ... hours/at ... UTC.

-Disabled and adrift

*I am not under command in position....
I am adrift near position....
I am drifting at ... knots to ... degrees.

*What kind of assistance do you require?
I require tug assistance.
I require....

-Armed attack/piracy

*I am under attack of pirates.
MV ... under attack of pirates.
I require assistance.
MV ... requires assistance.

*I was under attack of pirates.
MV ... was under attack of pirates.

*What kind of assistance do you require?
I require medical assistance.
I require navigational assistance.
I require tug assistance.
I require military assistance.
I require escort.
I require....

*What is damage?
I have no damage.
I have major/minor damage to navigational instruments.
I am not under command.

*Can you proceed?
Yes, I can/ will proceed.
No, I cannot/ will not proceed.

-Undesignated distress

*I have problems.
What problems have you?
I have problems with cargo.
I have problems with machinery.
I have problems with navigation.
I have problems with mass disease.
I have problems with....

*What kind of assistance do you require?
I require....

-Abandoning vessel

*I must abandon vessel after collision in position....
I must abandon vessel after grounding in position....
I must abandon vessel after flooding in position....
I must abandon vessel after explosion in position....
I must abandon vessel after piracy in position....
I must abandon vessel after ... in position....

2.1.1.2. Search and Rescue Communications

-Distress/urgency messages

*I require assistance.
I proceed to your assistance.

*What is your position?
My position....

*What is your present course and speed?
My present course ... degrees, my speed ... knots.

*How many persons on board?
Number of persons on board:

*Report injured persons.
No person injured
Number of injured persons/casualties:

*Will you abandon vessel?

I will not abandon vessel.

I will abandon vessel at...

*How many lifeboats/life rafts will you launch?

I will launch ... lifeboats/life rafts.

*How many persons will stay on board?

No person will stay on board.

... Persons will stay on board.

*What is weather situation in your position?

Wind ... (*direction*) force Beaufort....

Visibility ... meters/nautical miles.

Sea/swell ... meters from ... (*compass points*).

Current ... knots to ... degrees.

*Are there dangers to navigation?

No, no dangers to navigation.

Yes, uncharted rocks.

Yes, drifting ice.

Yes, abnormally low tides.

Yes, drifting mines.

Yes...

Proceed with caution.

-Acknowledgement and/or relay of SAR - messages

*Received MAYDAY from MV ... at UTC on channel.../frequency....

Vessel in position ... on fire/had explosion.

Vessel in position ... flooded.

Vessel in position ... has collided (with ...).

Vessel in position ... listing/in danger of capsizing.

Vessel in position ... sinking.

Vessel in position ... disabled and adrift.

Vessel in position ... abandoned.

Vessel requires assistance.

*Received your MAYDAY.

My position....

I proceed/MV ... proceeds to your assistance.

*When will you/assistance arrive?

I/assistance will arrive within ... hours/at ... UTC.

-Performing/coordinating SAR operations

*This is MV....

I am/will act as Co-coordinator Surface Search.

I will show following signals/lights.

*Can you proceed to distress position?

Yes, I can proceed to distress position.

No, I cannot proceed to distress position.

*When will you arrive at distress position?

I will arrive at distress position within ... hours/ at ... UTC.

*The position given in MAYDAY not corrects.

Correct position....

*Vessels are advised to proceed to position ... to start rescue.

Carry out search pattern ... starting at ... UTC.

Carrying out search pattern ... starting at ... UTC.

Initial course ... degrees, search speed ... knots.

Carry out radar search.

Carrying out radar search.

*MV ... is allocated track number....

MV/MVs ... adjust interval between vessels to ...kilometers/nautical miles.

Interval between vessels adjusted to ... kilometers/nautical miles.

*Adjust track spacing to ...kilometers/nautical miles.

Track spacing adjusted to ... kilometers/nautical miles.

Search speed now ... knots.

Alter course to ... degrees (at ... UTC).

Course altered to ... degrees (at ... UTC).

Alter course for next leg of track now/at ... UTC.

Course altered for next leg of track.

We resume search in position....

Crew has abandoned vessel.

Keep sharp lookout for lifeboats/life rafts.

-Finishing with SAR - operations

*What is result of search?

Result of search negative.

Continue search in position....

Sighted vessel in position....

Sighted derelict in position....

Sighted lifeboats/life rafts in position....

Sighted lifejackets in position....

Sighted oil slick in position....

Sighted ... in position.

*Can you pick up survivors?

Yes, I can pick up survivors.

No, I cannot pick up survivors.

*I/MV ... will proceed to pick up survivors.

Stand by at lifeboats/life rafts.

Picked up ... survivors in position....

Picked up ... lifejackets in position....

Picked up ... in position....

Picked up lifeboat/life raft with ... casualties in position....

Picked up ... casualties in lifejackets in position....

Survivors in bad/good condition.

*Do you require medical assistance?

Yes, I require medical assistance.

No, I do not require medical assistance.

*Try to obtain information from survivors.

There are still .../no more lifeboats/life rafts with survivors.

Total number of persons on board was....

Rescued all persons/ ... persons.

You/MV ... can stop search and proceed.

There is no hope to rescue more persons.

We finish with SAR - operations.

2.1.1.3 Person Overboard

*I/MV ... lost person overboard in position....

Assist with search in vicinity of position....

All ships in vicinity of position ... keep sharp lookout and report to....

I am/MV ... proceeding for assistance and, arriving at ... UTC.

*Search in vicinity of position....
I am/MV ... searching in vicinity of position....
Aircraft arriving within ... hours to assist in search.

*Can you continue search?
Yes, I can continue the search.
No, I cannot continue search.

*Stop search and return to base
Search stopped - returning to base.
Stop search and proceed your voyage.
Search stopped - proceeding my voyage.

*What is result of search?
Result of search negative.
I/MV ... located person in position....
I/MV ... picked up person in position....
Person picked up is crewmember of MV....
What is condition of person?
Condition of person bad/good.
Person dead.

2.1.1.4. Requesting Medical Assistance

*I require medical assistance.
What kind of assistance do you require?
I require boat for hospital transfer.
I require radio medical advice.
I require helicopter with doctor.
I require helicopter to pick up person.

*I will arrange for boat.
I will arrange for medical advice on channel ... /frequency....
I will arrange for helicopter.
Boat/helicopter will arrive within ... hours/at ... UTC.

*Have you doctor on board?
Yes, I have doctor on board.
No, I have no doctor on board.

*Can you make rendezvous in position...?
Yes, I can make rendezvous in position ... within ... hours/at ... UTC.
No, I cannot make rendezvous.
I will send boat/helicopter to pick up doctor.
Transfer person to my vessel by boat/helicopter.

2.1.2. Urgency Communications

2.1.2.1 Urgency Communications and Their Types

-Engine and equipment

*I am not under command in position....
What problems do you have?
I have problems with main engine.
I have problems with steering gear.
I have problems with propeller.
I have problems with....
I am maneuvering with difficulty.
Keep clear of me.
Navigate with caution.
Vessel not under command in position....
I require tug assistance.
I try to proceed without assistance.
I require escort.
Keep in contact on VHF channel....
Aircraft made forced landing near position....
Vessels in vicinity of position ... keep sharp lookout (for ...).

-Cargo

*I have lost dangerous substance of IMO-Class ... in position....
MV ... lost dangerous substance of IMO-Class ... in position....
Containers with dangerous substance of IMO-Class ... adrift near position....
Barrels/drums with dangerous substance of IMO-Class ... adrift near position....
Bags with dangerous substance of IMO-Class ... adrift near position....
... With dangerous substance of IMO-Class ... adrift near position....
I am/MV ... spilling dangerous substance of IMO-Class ... in position...
I am/MV ... spilling crude oil in position....
Require oil clearance assistance - danger of pollution imminent.
MV ... in position ... requires oil clearance assistance - danger of pollution.
I am /MV ... dangerous source of radiation.

-Ice damage

*I have/MV ... has major damage above/below waterline.
Extent of damage unknown.
What kind of assistance do you require?
.I requires medical assistance.
I require tug assistance.
I require ice-breaker assistance.

*Can you proceed without assistance?
Yes, I can proceed without assistance.
No, I cannot proceed without assistance.
Stand by on VHF channel....
Standing by on VHF channel....

2.1.3. Safety Communications

2.1.3.1. Warnings Involving Meteorological and Hydrological Conditions

-Winds, storms, tropical storms, sea state

*What is wind direction and force in your position/in position...?
Wind direction ... (*compass points*), force Beaufort ... in my position/in position... .
Is wind backing/veering?
Wind backing/veering.
What wind direction and force is expected in my position/in position...?
Wind in your position/in position ...expected from ... direction(s), force Beaufort...
Wind in your position/in position ...expected variable.
Is wind expected to increase/decrease?
Wind expected to increase/decrease.
Direction ... (*compass points*) and force Beaufort ... backing/veering to ... (*compass points*).
What is latest tropical storm warning?
Latest tropical storm warning is as follows:

- (Standard tropical storm warning)

*Tropical storm warning at...UTC. Hurricane...(name)/tropical cyclone/tornado/willy-willy/typhoon... with central pressure of ... mill bars located in position Present movement... (*Compass points*) at ... knots. Winds of ... knots within radius of ... miles of center. Seas over. Meters. Further information on VHF channel .../frequency....

*What is atmospheric pressure in your position/in position...?
Atmospheric pressure ... mill bars.
What is barometric change in your position/in position...?
Barometric change ... mill bars per hour.
Barometric change... mill bars within last ... hours.
Barometer steady.
Barometer dropping (rapidly).
Barometer rising (rapidly).
What is position, path and speed of advance of tropical storm... (Name)?

*What maximum winds are expected in storm area?
Maximum winds of ... knots expected in storm area.
Maximum winds of ... knots expected within radius of ... kilometers/miles of center.
Maximum winds of ... knots expected in ... safe/dangerous semicircle.

*What is sea state in your position/in position...?
Sea/swell in my position/in position meters from... (*Compass points*)

*Is sea state expected to change (within next hours)?
No, sea state not expected to change (within next hours).
Yes, sea/swell of ... meters from ... (*compass points*) *expected* (within next hours).
Tsunami/abnormal wave expected by ... UTC.

-Restricted visibility (due to mist/fog, precipitation)

*What is visibility in your position/in position...?
Visibility in my position/in position meters/nautical miles
Visibility reduced by mist/fog/snow/dust/rain.
Visibility increasing/decreasing/variable.
Is visibility expected to change in my position/in position ... (within next hours)?
No, visibility not expected to change in your position/in position... (Within next hours).

-Ice

*What is latest ice information?
Ice warning. Ice/iceberg(s) located in position ... /reported in area around....
No ice located in position ... /reported in area around....
What kind of ice was located in position ... /reported in area around...?
I/MV ...located ... in position ... /reported ... in area around....

*What ice situation is expected in my position/area around...?
Ice situation expected/not expected to change in your position / area around....
Ice situation expected to improve/deteriorate in your position / area around....
Ice expected to break up in your position/ area around....
Ice expected to open in your position / area around....
Ice expected to drift away in your position / area around....
Ice expected to freeze together in your position /area around....

*Thickness of ice expected to increase/decrease in your position /area around....
Navigation dangerous in area around ... due to floating ice/ pack ice/ iceberg(s).
Navigation in area around ... without ice-breaker assistance only possible for high-powered vessels of strong construction.

-Volcanic activities including earth and seaquakes

*Volcanic activities expected in position ... / area around....

Earthquake/seaquake expected in position ... / area around....

Tsunami/abnormal wave expected in position ... / area around....

Move to high seas - keep off coast.

-Abnormal tides

*Present tide... meters above datum in position....

Tide ... above/below prediction.

Tide rising/falling.

Wait until high/low water.

Abnormally high/low tides expected in position ... at about ... UTC/within ... hours.

Is sufficient depth of water in position...?

Yes, sufficient depth of water in position....

No, not sufficient depth of water in position....

Depth of water ... meters in position....

My draft ... meters - can I enter/pass ... (*charted name of place*)?

Yes, you can enter/pass (*charted name of place*).

No, you cannot enter/pass (*charted name of place*) at present - wait until ... UTC.

Charted depth of water increased/decreased by ... meters due to sea state/winds.

2.1.3.2. Navigational Warnings and Their Types

-Land or Sea marks

-Defects

*(Charted name of light/buoy)... (Position) unlit.

(Charted name of light/buoy)... (Position) unreliable.

(Charted name of buoy)... (Position) damaged.

(Charted name of light)... (Position) destroyed.

(Charted name of buoy)... (Position) off station.

(Charted name of buoy)... (Position) missing.

For major lights only: Fog signal at ... (charted name of light) ... (position) inoperative.

-Alterations

(*Charted name of light/buoy*)... (*Position*) changed to ... (*full characteristics*).

(*Charted name of light/buoy*)... (*Position*) temporarily changed to ... (*full characteristics*).

(*Charted name of buoy*)... (*Position*) temporarily removed (when appropriate).

(*Charted name of light*)... (*Position*) temporarily discontinued (when appropriate).

-New and moved

**(Charted name of light/buoy)... (Full characteristics) established in position....
(Charted name of light)... (Full characteristics) re-established in position....
(Charted name of light/buoy) moved ... (in miles and decimal miles)... (Direction) to
position*

-Drifting objects

**Super buoy adrift in vicinity ... (position) at ... (date time if known).
Hazardous mine adrift in vicinity ... (position) at ... (date time if known).
Unlit derelict vessel adrift in vicinity ... (position) at ... (date time if known).
(Number) containers adrift in vicinity ... (position) at ... (date time if known)*

-Electronic navigation aids

*GPS Satellite ... (number) unusable from ... (date and time) to ... (date and time).
Cancel one hour after time of restoration.
LORAN station ... (name number master/slave) off air from ... (date and time) to ...
(date and time).*

-Sea bottom characteristics, wrecks

**(Use REPORTED when position is unconfirmed, and use LOCATED when
position has been confirmed by survey or other means)*

**Uncharted reef/rock/shoal reported in position....
Dangerous wreck/obstruction located in position....
Dangerous wreck in position... marked by ... (type) buoy ... (distance in
kilometers/nautical miles) ... (direction).*

-Miscellaneous

-Cable, pipeline and seismic/hydrographic operations

**Cable/pipeline operations by ... (vessel) in vicinity/along line joining ... (position)
from
... (Date time) to ... (date time). Wide berth requested. (if requested). Contact via
VHF
Channel ... (number). (If requested Seismic survey/hydrographic operations by ...
(vessel) from ... (date time) to... (Date time)*

-Diving operations, tows

**Diving operations by vessel ... (name) from ... (date time) to ... (date time)
in position Wide berth requested (if requested).*

*Difficult tow from ... (port of departure) on ... (date) to ... (destination) on ... (date).
Wide berth requested.*

-Tanker transshipment

*Transshipment of ... (*kind of cargo*) in position.... Wide berth requested.
I am/MT ... spilling oil/chemicals/... in position....Wide berth requested.
I am/LNG-tanker ... leaking gas in position... - do not pass to windward.
Oil clearance operations near MT ... in position.... Wide berth requested.

-Off-shore installations, rig moves

*Platform ...(*name/number if available*) reported/established in position... at ... (*date and time*).Wide berth requested. (If requested).

Platform ...(*name/number if available*) removed from ... (*position*) on ... (*date*).
Pipeline/platform ...(*name/number if available*) in position ... spilling oil/leaking gas.
Wide berth requested. Derelict platform ...(*name/number if available*) being removed from ... (*position*) at ... (*date time*).Wide berth requested.

-Defective locks or bridges

*Lock ... (*name*) defective.
For entering ... (*charted name of place*) use lock ... (*name*).
Lock/Bridge ... (*name*) defective.
Avoid this area - no possibility for vessels to turn.

-Military operations

*Gunnery/Rocket firing/missile/torpedo/underwater ordnance exercises in area bounded
By ... (*positions*) from ... (*date and time*) to... (*Date and time*). Wide berth requested.
(If requested).
Mine clearing operations from ... (*date time*) to ... (*date time*) in area bound
By ... (*positions*).Wide berth requested. Contact via VHF channel ... (*number*). (if requested).

-Fishery

*Small fishing boats in area around .../within ...nautical miles of me - navigate with caution. Is fishing gear ahead of me? No, no fishing gear ahead of you. Yes, fishing gear with buoys/without buoys ahead of you - navigate with caution.
Yes, fishing gear in position .../area around ...- navigate with caution.
Fishing gear fouled my propeller(s).
You have caught my fishing gear.
Advise you to recover your fishing gear.
Fishing in area ... prohibited.
You are approaching prohibited fishing area.

2.1.3.3. Environmental Protection Communications

*Located oil spill in position ... extending ... (*length and width in meters*) to ... (*compass points*).

Located oil spill in your wake.
I have accidental spillage of oil/....

*Can you stop spillage?
Yes, I can stop spillage.
No, I cannot stop spillage.

*What kind of assistance do you require?
I require oil clearance assistance.
I require floating booms/oil dispersants/....
Stay in vicinity of pollution and co-operate with oil clearance team.
(*Number*) barrels/drums/containers with IMDG - Code marks reported adrift near position.....

Located vessel dumping chemicals/waste/ ... in position....
Located vessel incinerating chemicals/waste/ ... in position....
Can you identify polluter?
Yes, I can identify polluter - polluter MV....
No, I cannot identify polluter.
What is course and speed of polluter?
Course of polluter ... degrees, speed ... knots.
Polluter left scene.

2.1.4. Pilotage

-Pilot request

*Must I take pilot?
Yes, you must take pilot - pilotage compulsory.
No, you need not take pilot.

*Do you require pilot?
Yes, I require pilot.
No, I do not require pilot - I am holder of Pilotage Exemption Certificate (No. ...).
You are exempted from pilotage.

*Do you require pilot at ... (*name*) Pilot Station?
Yes, I require pilot at ... (*name*) Pilot Station.
No, I do not require pilot at ... (*name*) Pilot Station - I require pilot in position... .

*What is your ETA at ... (*name*) Pilot Station in local time?
My ETA at ...(*name*) Pilot Station ... hours local time.

*What is local time?

Local time ... hours.

*What is your present position?

My position....

*What is your distance from ...(*name*) Pilot Station?

My distance from ... (*name*) Pilot Station ... kilometers/nautical miles.

*Is pilot boat on station?

Yes, pilot boat on station.

No, pilot boat not on station.

*Pilot boat on station at ... hour's local time.

In what position can I take pilot?

Take pilot in position ... at ... hour's local time.

Take pilot near ... at ... hour's local time.

When will pilot embark?

Pilot will embark at ... hour's local time.

*Pilot coming to you.

Pilot boat approaching your vessel.

Keep pilot boat on port side.

Keep pilot boat on starboard side.

What is your freeboard?

My freeboard ... meters.

Stop in present position and wait for pilot.

Change to VHF channel ... for pilot transfer.

Stand by on VHF channel ... until pilot transfer completed.

Pilotage at ... (*name*) Pilot Station suspended until ... (*date and local time*).

Pilotage at ... (*name*) Pilot Station resumed.

Pilot cannot embark at ... (*name*) Pilot Station due to....

Do you accept shore based navigational assistance from pilot?

Yes, I accept shore based navigational assistance from pilot.

I stay in position ... until....

You may navigate by yourself (or wait for pilot at ... buoy).

Follow pilot boat inward where pilot will embark.

-Embarking/disembarking pilot

*Stand by pilot ladder.

Rig pilot ladder on port side ... meters above water.

Rig pilot ladder on starboard side ... meters above water.

Pilot ladder on port side.

Pilot ladder on starboard side.

*You must rig another pilot ladder
Pilot ladder unsafe.
What is wrong with pilot ladder?
Pilot ladder has broken steps.
Pilot ladder has loose steps.
Pilot ladder has broken spreaders.
Pilot ladder has spreaders too short.
Pilot ladder too far aft.
Pilot ladder too far forward.

*Steer ... degrees to make lee.
Keep sea on your port quarter.
Keep sea on your starboard quarter.
Make boarding speed of ... knots.
Stop engine until pilot boat is clear.
Put helm hard to port.
Put helm hard to starboard.
Alter course to port - pilot boat cannot clear vessel.
Alter course to starboard - pilot boat cannot clear vessel.
Put ahead engine.
Put astern engine.
Embarkation not possible.
Boarding arrangements do not comply with SOLAS - Regulations.
Vessel not suited for pilot ladder.

-Tug assistance

*How many tugs do you require?
I require ... tug(s).
Must I take tug(s)?
Yes, you must take ... tug(s).
No, you need not take tug(s).
How many tugs must I take?
You must take ... tug(s) according to Port Regulations.
You must take ... tug(s) fore and ... tug(s) aft.
I will order tug(s).
In what position will tug(s) meet me?
Tug(s) will meet you in position ... at ... local time.
Wait for tug(s) in position....
Must I take my towing lines?
Yes, you must take your towing lines.
No, you must take towing lines of tug.
Tug services suspended until ... (*date and local time*).
Tug services resumed on ... (*date*) at ...local time.

2.1.5. Specials

2.1.5.1 Helicopter operations

(H: = from helicopter V: = from vessel)

V:	I require helicopter.
V	I require helicopter to pick up persons.
V	I require helicopter with doctor.
V	I require helicopter with raft.
V	I require helicopter with....
H:	MV ..., I will drop....
H:	MV ..., are you ready for helicopter?
V	Yes, ready for helicopter.
V	No, not ready for helicopter (yet).
V	Ready for helicopter in ... minutes.
H:	MV ..., helicopter is on way to you.

Table.2.1. Helicopter between vessel communications

2.1.5.2. Ice Breaker Operations

-Ice breaker request

*I am fast on ice in position....

I require ice-breaker assistance to....

Ice-breaker assistance will arrive at ...hour's local time /within ... hours.

Ice-breaker assistance not available until ...hour's local time.

Ice-breaker assistance available only up to latitude... longitude....

Ice-breaker assistance suspended until... (*Date and local time*).

Ice-breaker assistance suspended after sunset.

Ice-breaker assistance suspended until favorable weather conditions.

Ice-breaker assistance resumed at ...hour's local time.

-Ice breaker assistance for convoy

*(Ice-breaker commands applying to all the vessels in a convoy have to be immediately obeyed and confirmed consecutively by each vessel in turn. Ice-breaker commands applying to a single vessel are confirmed only by that vessel, this applies also for close coupled towing.)

*Ice breaker assistance for convoy will start now / at ...hours local time..

Stand by on VHF channel....

Standing by on VHF channel....

Keep lookout for sound and visual signals.

Keeping lookout for sound and visual signals.

-Ice breaker assistance in close coupled towing

*Stand by for close coupled towing.

Standing by for close coupled towing.

Veer out your anchors under hawse-pipes.

Anchors veered out under hawse-pipes.

Pass heaving lines through hawse-pipes.

Heaving lines passed through hawse-pipes.

Receive towing line on deck.

Towing line received on deck.

Lash together eyes of towing line with manila lashing.

Eyes of towing line lashed with manila lashing.

2.1.6. Vessel Traffic Service (VTS) Standard Phrases

2.1.6.1 Application of Message Markers

In order to especially facilitate shore-to-ship and ship-to-shore communication or radio communication in general or when one of the Standard Marine Communication Phrases will not fit the meaning desired, one of the following eight **Message Markers** may be used to increase the probability of the purpose of the message being properly understood.

It is at the discretion of the shore personnel or the ship's officer whether to use one of the message markers and if so which of them to apply depending on his/her qualified assessment of the situation.

If used the message marker is to be spoken preceding the message or the corresponding part of the message. The IMO VTS Guidelines recommend that in any message directed to a vessel it should be clear whether the message contains information, advice, warning, or instruction and IMO Standard Marine Communication Phrases should be used where practicable.

For further standardized VTS communications also see other sections of PART III. For VTS Standard Reporting Procedures see "IMO resolution A.648(16) on general principles for ship reporting systems and ship reporting requirements, including guidelines for reporting incidents involving dangerous goods, harmful substances and /or marine pollutants".

All of the following phrases must come as the culmination (message content) of a radio message exchange between two stations in the Maritime Mobile Service, as laid down by the ITU Regulation. Definite instructions on how to carry out these procedures may be found in the Sea speak Training Manual (ISBN 0 08 031555 0).

-INSTRUCTION

This indicates that the following message implies the intention of the sender to influence others by a Regulation.

This means that the sender, e.g. a VTS - Station or a naval vessel, must have the full authority to send such a message. The recipient has to follow this legally binding message unless s/he has contradictory safety reasons which then have to be reported to the sender.

Example: "INSTRUCTION. (You must) alter course."

-ADVICE

This indicates that the following message implies the intention of the sender to influence others by a Recommendation. The decision whether to follow the ADVICE still stays with the recipient. One does not necessarily have to carry out the ADVICE, but should consider it very carefully.

Example: "ADVICE. (Advise you) stand by on VHF channel six nine."

-WARNING

This indicates that the following message implies the intention of the sender to inform others about danger.

This means that any recipient of a WARNING should pay immediate attention to the danger mentioned. Consequences of a WARNING will be up to the recipient.

Example: "WARNING. Obstruction in fairway"

-INFORMATION

This indicates that the following message is restricted to observed facts, situations, etc...

Comment: This marker is preferably used for navigational and traffic information, etc...

Consequences of INFORMATION will be up to the recipient.

Example: "INFORMATION. Tanker stop in area Cod End Bank due to poor visibility."

-QUESTION

This indicates that the following message is of interrogative character.

The use of this marker removes any doubt on whether a question is being asked or statement being made, especially when interrogatives such as What, Where, Why, Who, How are additionally used at the beginning of the question. The recipient is expected to return an answer.

Example "QUESTION.(What is) your draft?"

-ANSWER

This indicates that the following message is the reply to a previous answer. Comment: Note that an answer should not contain another question. Example: "ANSWER. My maximum draft seven meters."

-REQUEST

This indicates that the following message is asking for action from others with respect to the vessel. Comment: The use of this marker is to signal: I want something to be arranged or provided,

e.g. ship's stores requirements, tugs, permission, etc..

Note: REQUEST must not be used involving navigation, or to modify COLREGS. Example: "REQUEST. (Please) supply bunkers."

-INTENTION

This indicates that the following message informs others about immediate navigational action intended to be taken.

The use of this message marker is logically restricted to messages announcing navigational actions by the vessel sending this message.

Example: "INTENTION. I will reduce speed."

➤ **Phrases for Acquiring and Providing Data for a Traffic Image**

-Acquiring and providing routine traffic data

The following phrases should normally be preceded by Message Markers "QUESTION", "ANSWER", "INFORMATION"

- What is your name, call sign/identification?
- My name, call sign/identification.....
- What is your flag state?
- My flag state.....
- What is your position?
- My position.....
- What is your full maneuvering speed?
- My full maneuvering speed knots.

- What is your cargo?
- My cargo.....

➤ **Phrases for Providing VTS Services**

-Information Service

These phrases are normally transmitted from the shore.

-Navigational Warnings

(The following phrases should normally be preceded by the Message Marker “WARNING”)

- Unknown object(s) in position....
- Ice/iceberg(s) in position ... /area around....
- Unlit derelict vessel adrift in vicinity ... at ... (*date and time*).
- Dangerous wreck/obstruction located in position ... marked by ... (*type*) buoy.
- Hazardous mine adrift in vicinity ... at ... (*date and time*).
- Uncharted reef/rock/shoal reported in position....
- Pipeline leaking gas/oil in position ... - wide berth requested.
- No sufficient depth of water in position....
- U.N. exclusion zone extending ... kilometers/nautical miles from ...- all vessels keep clear.
- Navigation closed in area....

➤ **Phrases Between Adjacent VTS**

-Handoff Procedures (Handing over to another VTS).

The following phrases should normally be preceded by Message Marker INFORMATION

- ... VTS this is ... VTS: MV ... position ... degrees, distance ... kilometers/nautical miles from.... Working Frequency VHF Channel.... You're Target. Please Confirm.
- ... VTS this is ... VTS: MV ... position ... degrees, distance ... kilometers/nautical miles from.... I confirm. My target.
- ... VTS this is ... VTS: MV ... position ... degrees, distance ... kilometers/nautical miles from.... I am unable to take over this target.

➤ **2.1.6.1.4. Phrases for Communication with Emergency Services and Allied Services**

-Emergency Services (SAR, fire fighting, pollution fighting)

-Tug assistance

The following phrases should normally be preceded by Message Markers "INSTRUCTION", "ADVICE", "INFORMATION", "QUESTION", "ANSWER"

- How many tugs do you require?
- I require ... tug(s).
- You must take ... tug(s) according to Port Regulations.
- You must take ... tug(s) fore and ... tug(s) aft.
- Wait for tug(s) in position....
- Tugs will meet you in position ... at ... local time.
- Tug services suspended until ... (*date and local time*).
- Tug services resumed on...(date) at ... local time

-Pilotage and Pilot Request

The following phrases should normally be preceded by Message Markers "ADVICE", "INFORMATION", "REQUEST", "INTENTION", "QUESTION", "ANSWER"

- You must take pilot - pilotage compulsory.
- Do you require pilot?
- Yes, I require pilot.
- No, I do not require pilot - I am holder of Pilotage Exemption Certificate (No. ...).
- You are exempted from pilotage.
- You are allowed to proceed without pilot.
- Do you require pilot at ... (*name*) Pilot Station?
- Yes, I require pilot at ... (*name*) Pilot Station.
- No, I do not require pilot at ... (*name*) Pilot Station - I require pilot in position....
- What is your ETA at ... (*name*) Pilot Station in local time?
- My ETA at... (*Name*) Pilot Station ... hour's local time.
- What is local time?
- Local time ... hours.
- What is your present position?
- My position....
- What is your distance from ... (*name*) Pilot Station?
- My distance from ... (*name*) Pilot Station ... kilometers/nautical miles.

- Is pilot boat on station?
- Yes, pilot boat on station.
- No, pilot boat not on station.
- Pilot boat on station at ... hour's local time.
- In what position can I take pilot?
- Take pilot at ... (*Pilot Station*) at ... hour's local time.
- -Take pilot near ... at ... hour's local time.
- -When will pilot embark?
- -Pilot will embark at ... hour's local time.
- -Pilot coming to you.
- Pilot boat approaching your vessel.
- Keep pilot boat on port side.
- Keep pilot boat on starboard side.
- What is your freeboard?
- My freeboard ... meters.
- Stop in present position and wait for pilot.
- Change to VHF channel ... for pilot transfer.
- Stand by on VHF channel ... until pilot transfer completed.
- Pilotage at ... (*name*) Pilot Station suspended until ... (*date and local time*).
- Pilotage at ... (*name*) Pilot Station resumed.
- Pilot cannot embark at ... Pilot Station due to....
- Do you accept shore based navigational assistance from pilot?
- Yes, I accept shore based navigational assistance from pilot.
- No, I do not accept shore based navigational assistance from pilot.
- I stay in position ... until....
- You may navigate by yourself (or wait for pilot boat at ... buoy).
- Follow pilot boat inward where pilot will embark.

-Embarking/diseimbarking Pilot

The following phrases should normally be preceded by Message Markers "ADVICE", "INFORMATION", "REQUEST", "INTENTION", "QUESTION", "ANSWER"

- Stand by pilot ladder.
- Rig pilot ladder on port side ... meters above water.
- Rig pilot ladder on starboard side ... meters above water.
- You must rig another pilot ladder.
- Pilot ladder unsafe.
- Pilot ladder has broken steps.
- Pilot ladder has loose steps.
- Pilot ladder has broken spreaders.

- Pilot ladder has spreaders too short.
- Pilot ladder too far aft.
- Pilot ladder too far forward.
- Move pilot ladder ... meters aft.

2.2. ON BOARD COMMUNICATION PHRASES

2.2.1. Operative Ship Handling

2.2.1.1. Standard Wheel Orders

All wheel orders given should be repeated by the helmsman and the officer of the watch should ensure that they are carried out correctly and immediately. All wheel orders should be held until countermanded. The helmsman should report immediately if the vessel does not answer the wheel. When there is concern that the helmsman is inattentive s/he should be questioned:

"What is your course?" And s/he should respond: "My course ... degrees."

ORDER

MEANING

1. Midships	Rudder to be held in the fore and aft position.
2. Port five	5 ⁰ of port rudder to be held.
3. Port ten	10 ⁰ of port rudder to be held.
4. Port fifteen	15 ⁰ of port rudder to be held.
5. Port twenty	20 ⁰ of port rudder to be held.
6. Port twenty-five	25 ⁰ of port rudder to be held.
7. Hard -a-port	Rudder to be held fully over to port.
8. Starboard five	5 ⁰ of starboard rudder to be held.
9. Starboard ten	10 ⁰ of starboard rudder to be held.
10. Starboard fifteen	15 ⁰ of starboard rudder to be held.
11. Starboard twenty	20 ⁰ of starboard rudder to be held.
12. Starboard twenty-five	25 ⁰ of starboard rudder to be held.
13. Hard-a- starboard	Rudder to be held fully over to starboard.
14. Ease to five	Reduce amount of rudder to 5 ⁰ and hold.
15. Ease to ten	Reduce mount of rudder to 10 ⁰ and hold
16. Ease to fifteen	Reduce amount of rudder to 15 ⁰ and hold.
17. Ease to twenty	Reduce amount of rudder to 20 ⁰ and hold.
18. Steady	Reduce swing as rapidly as possible.
19. Steady as she goes	steer a steady course on the compass heading indicated at the time of the order. The helmsman is to repeat the order and call out the compass heading on receiving the order. When the ship is steady on that heading, the helmsman is to call out: "Steady on ..."

20. Keep buoy/ mark/ beacon/ ... on port side.
21. Keep buoy/ mark/ beacon/ ... on starboard side.
22. Report if she does not answer wheel.
23. Finished with wheel.

When the officer of the watch requires a course to be steered by compass, the direction in which s/he wants the wheel turned should be stated followed by each numeral being said separately, including zero, for example:

2.2.1.2. Standard Engine Orders

Any engine order given should be repeated by the person operating the bridge telegraph(s) and the officer of the watch should ensure the order is carried out correctly and immediately.

ORDER

1. Full ahead
2. Half ahead
3. Slow ahead
4. Dead slow ahead
5. Stop engine(s)
6. Dead slow astern
7. Slow astern
8. Half astern
9. Full astern
10. Emergency full ahead
11. Emergency full astern
12. Stand by engine

(Engine-room personnel fully ready to maneuver and bridge manned to relay engine orders.)

13. Finished with engine(s)
(Movement of engine(s) no longer required.)

In vessels fitted with twin propellers, the word "both" should be added to all orders affecting both shafts, e.g. "Full ahead both", and "Slow astern both", except that the words "Stop all engines" should be used, when appropriate. When required to manoeuvre twin propellers independently, this should be indicated, i.e. "Full ahead starboard", "Half astern port", etc.

Where bow thrusters are used, the following orders are used:

14. Bow thrust full /half to port side.

15. Bow thrust full/half to starboard side.
16. Stern thrust full /half to port side.
17. Stern thrust full/half to starboard side.
18. Bow /stern thrust stop

2.2.1.3. Handover of Watch keeping Responsibilities

-Briefing on position, movement and draft

-Position

- Present position latitude ..., longitude....
- Present position bearing ... degrees, distance ... kilometers/nautical miles.
- Present position buoy ... (*charted name*).
- Present position between ... and... .
- Present position DECCA ..., and....
- Present position way point/ reporting point....
- Present position....
- Next way point/ reporting point/....
- ETA at UTC/local time.
- Passing buoy ... (*charted name*) on port side/ starboard side.
- Passed buoy ... (*charted name*) on port side/starboard side.
- Approaching buoy ... (*charted name*) on port side/ starboard side.
- Buoy ... (*charted name*) ... kilometers/ nautical miles ahead.
- Entering area....
- Entered area....
- Leaving area....
- Left area....

-Movements

- True course ... degrees.
- Gyro compass course ... degrees.
- Magnetic compass course ... degrees
- Gyro compass error ... degrees plus/minus.
- Magnetic compass error ... degrees east/west.
- Speed over ground....
- Speed through water....
- Set and drift ... degrees, knots.
- Making ... degrees leeway.
- Course board written up.
- Next chart within.... hours.

2.2.1.4. Trim, List and Stability

- Vessel on even keel (at present).
- Vessel ... meters down by the head /by the stern (at present).
- No list (at present).
- (Present) list ... degrees to port side/ starboard side.
- Fuel/ ballast/ fresh water/ oil transferred from (no.) ... tank(s)
- to (no.) ... tank(s) to correct list.
- We must transfer fuel/ ballast/ fresh water/ oil from (no.) ... tank(s)
- to (no.) ... tank(s) to correct list.
- Cargo restored in (no.) ... hold(s) to correct list.
- Deck cargo restored to correct list.
- We must restow cargo in (no.) ... hold(s) to correct list.
- (Present) stability good.
- (Present) stability poor.
- Double bottom tank(s) filled to improve stability.

2.2.1.5. Pilot on the Bridge

2.2.1.6. Propulsion System

- Is engine diesel or turbine?
- Engine is diesel.
- Engine is turbine.
- Is engine - room manned or is engine on bridge control?
- Engine - room manned.
- Engine on bridge control.
- How long does it take to change engine from ahead to astern?
- It takes ... minutes to change engine (from ahead to astern).
- How long does it take to start engine from stop
- It takes ... seconds to start engine (from stopped).
- Is extra power available in emergency?
- Yes, extra power available.
- No, extra power not available.

2.2.1.7. Maneuvering

- I require pilot card/ maneuvering data.
- What is diameter of turning circle?
- Diameter of turning circle ... meters.
- What is advance and transfer distance in crash-stop?
- Advance ... kilometers/ nautical miles, transfer distance ... degrees (in crash-stop).
- How long does it take from hard-a-port to hard-a-starboard?
- It takes ... minutes (from hard-a-port to hard-a-starboard).
- Is turning effect of propeller very strong?

- Whistle control on console.
- Whistle control on...
- What notice is required to reduce from full sea speed to maneuvering speed?
- ... Minutes notice required (to reduce from full sea speed to maneuvering speed).
- Do you have automatic pilot?
- Yes, we have automatic pilot.
- No, we have no automatic pilot.

2.2.1.8. Radar

- Is radar operational?
- Yes, radar operational.
- No, radar not operational.
- Has radar any blind sectors?
- Yes, radar has blind sectors from ... to ... degrees and from ... to ... degrees.
- No, radar has no blind sectors.
- Change radar to ... miles range scale.
- Change radar to relative head-up.
- Change radar to relative north-up.
- Change radar to relative course-up.
- Change radar to true-motion north-up.
- Change radar to true-motion course-up.

2.2.1.9. Draft and Air Draft

- What is (present) draft?
- Maximum draft ... meters.
- Draft forward ... meters.
- Draft aft ... meters.
- What is air draft?
- Air draft ... meters.

2.2.1.10 Anchoring

-Going to Anchor

- Stand by port/starboard/both anchor(s) for let go.
- Port/starboard/both anchor(s) standing by for let go.
- Walk out anchor(s)
- Anchor(s) walked out.
- We are going to anchorage.
- We will let go port/starboard/both anchor(s).
- Put ... shackles in water.
- Put ... shackles in pipe.

2.2.1.11 Tug assistance

- We will take ... tug(s).
- Tug(s) will pull/push.
- We take lines of vessel.
- We take line(s) of tug(s).
- Stand by for making fast tug(s).
- Standing by for making fast tug(s).
- Use center/panama lead.
- Use fairlead on port side/starboard side.
- Use fairlead amidships.
- Use fairlead on port bow/starboard bow.
- Use fairlead on port/starboard quarter.
- Send heaving line to tug.
- Send two towing lines to tug.
- Lower towing line(s) to tug.

2.2.1.12. Berthing and Unberthing

-General

- No, propeller not clear.
- Keep propeller clear.
- Stop propeller.
- Propeller stopped.
- Are fenders on berth.
- Yes, fenders on berth.
- No, no fenders on berth.
- Have fenders ready fore and aft.

-Berthing

- We will berth port side alongside.
- We will berth starboard side alongside.
- We will moor to buoy(s) ahead and astern.
- We will moor alongside.
- We will moor to dolphins.
- Send out head/ stern/ breast lines.
- Send out ... spring(s) forward.
- Send out ... spring(s) aft.
- Do you have tension winches?
- Yes, we have tension winches (forward and aft).
- No, we have no tension winches.
- Have heaving lines ready forward and aft.
- Send heaving/ head/ stern/ breast line ashore.

- The linesmen will use shackles/ lashings for securing mooring.
- Use center/ panama lead.
- Use bow lead.
- Use port quarter/starboard quarter lead.
- Heave on ... line(s)/ ... spring(s)..
- Pick up slack on ... line(s)/ ... spring(s)..
- Heave away

2.2.2. Safety on Board

2.2.2.1. General Activities

-Raising alarm

- Operate general emergency alarm.
- Inform Master / Chief engineer /....
- Master / Chief engineer / ... informed.
- Inform ... coast radio station / vessels in vicinity (on radio) and report.
- ... Coast radio station / vessels in vicinity informed.
- Request assistance (on radio) from ... and report.
- Assistance requested from....
- Assistance offered by....
- Assistance accepted from....
- Transmit SECURITE/PAN-PAN /distress alert/ MAYDAY and report.
- SECURITE/ PAN-PAN/distress alert/MAYDAY transmitted.
- Was distress alert/MAYDAY acknowledged?
- Yes, distress alert /MAYDAY acknowledged by ... coast radio station/RCC/vessel(s) in vicinity.
- No, distress alert not acknowledged (yet).
- Repeat distress alert.

-Briefing crew and passengers

(Also see: Chapter D: Passenger Care)

- Make following announcement (on PA - system):
- This is your Captain speaking.
- We have grounded / a minor flooding / a minor fire in... .
- There is no immediate danger to crew, passengers or vessel - and there is no reason to be alarmed.
- For safety reasons I request all crew members to go to their assembly stations.
- All officers to report to the bridge.
- Watch keepers remain at stations until further order.
- As soon as I have further information I will make another announcement - there is no danger at this time.
- Fire parties / damage control teams are fighting the fire / flooding.

- We also have radio contact with other vessels / coast radio stations.
- The fire / flooding is under control.
-
- This is your Captain speaking. I have another announcement:
- The fire/ flooding is not under control yet.
- Leave the engine room / superstructure / your stations / your cabins / ... immediately
- Close all openings.
- Take lifejackets with you.
- Take your emergency equipment with you according to muster list.
- Stand by fire fighting stations / damage control stations.
- Fire fighting stations/damage control stations standing by.
- All crew members to assembly stations.

-Checking status of lifeboats / life rafts

- Check launching tracks and report.
- All launching tracks clear.
- Launching track(s) of no. ...lifeboat / life raft not clear (yet).
- Launching track(s) of no. ... Lifeboat / life raft clear in ... minutes.
- Check working parts and report.
- All working parts free.
- Roll(s) / block(s) / rigging / ... of no. ...lifeboat not free (yet).
- Roll(s) / block(s) / rigging / ... of no. ... Lifeboat free in ... minutes.
- Check securing's of launching appliances and report.
- All securing's in correct position.
- Securing of no. ... Lifeboat / life raft not in correct position.
- Correct position of securing.

2.2.2.2 Occupational Safety

-Instructions

- Prepare training plan for occupational safety.
- Prepare training plan regarding type of vessel.
- Prepare training plan regarding kind of cargo.
- Prepare training plan regarding route of vessel.
- Prepare training plan regarding....
- When was last training session on occupational safety?
- Last training session was on ... (*date*).
- When is next training session on occupational safety?
- Next training session on ... (*date*).
- Next training session before entering port.
- Next training session after leaving port.
- Next training session in port of....

- Next training session is about accident analysis/new regulations/....
- Are new crew members/passengers instructed on occupational safety?
- Yes, new crew members/passengers instructed.
- No, new crew members/passengers not instructed (yet).
- Instruct new crew members/passengers by ... (*time*) / on ... (*date*).
- Participation in training sessions on occupational safety is mandatory.

-Practical Occupational Safety

- Instruct crew on occupational safety before departure.
- Instruct crew on occupational safety regarding type of vessel/kind of cargo/route of vessel/ ... before departure.
- Have special instruction on dangerous goods/ heavy lifts/cargo securing/illumination/ventilation/....
- Where are dangerous goods carried on board?
- Dangerous goods of IMO Class ... carried on deck (in roped-off areas).
- Dangerous goods of IMO Class ... carried in no. ... Hold.
- Dangerous goods of IMO Class ... carried in ... /on....
- Prepare emergency plan.
- Prepare emergency plan for first aid.

2.2.2.3. Fire Protection and Fire Fighting

-Fire protection and checking status of equipment

- Have fire patrols.
- Have fire patrols every ... hour(s).
- Have fire patrols ... time(s) every watch.
- Have fire patrols....
- Have permanent fire watch.
- Have fire patrols in all spaces/areas.
- Have fire patrols in engine room.
- Have fire patrols in cargo hold(s).
- Switch on/off fire/smoke alarms.
- Switch on /off fire/smoke alarms in all spaces.
- Switch on/off fire/smoke alarms in engine room.
- Switch on/off fire/smoke alarms in cargo hold(s)/tank(s).
- Switch on/off fire/smoke alarms in superstructure.
- Switch on /off fire/smoke alarms in accommodation.

2.2.2.4. Damage Control

- Check openings in engine room.
- Check openings in cargo hold(s) / **tank(s)** t.
- Check openings in double bottom.

- Check openings in superstructure.
- Check openings in accommodation.
- Check openings in ... compartment and report.
- Check openings in forepeak.
- Check openings in after peak.

-Check watertight door control and report

- Watertight door control operational.
- Watertight door control (in ...) not operational (yet).
- Watertight door control (in ...) operational in ... minutes.
- Watertight door(s) (in ...) not accessible.

-Check pumps and report

- (Bilge) pump(s) in engine room / no. ... Hold / tank(s) operational.
- (Bilge) pump(s) in engine room / no. ... Hold / tank(s) ... not operational (yet).
- (Bilge) pump(s) in engine room / no. ... Hold / tank(s) ... operational in ... minutes.

-Check emergency generator and report

- Emergency generator operational.
- Emergency generator not operational (yet).
- Emergency generator operational in ... minutes

2.2.2.5 Grounding

-Reporting groundings and ordering immediate actions

- Vessel aground.
- Stop engine(s).
- Engine(s) stopped.
- Close watertight doors and report.
- Watertight doors closed.
- Is vessel (still) making way ahead/astern?
- Yes, vessel making way ahead/astern.:
- No, vessel not making way.

2.2.2.6. Search and Rescue

-Checking equipment status

- Check lifebuoys and report.
- Lifebuoys complete and available.

- Lifebuoys not complete.
- Lifebuoy(s) at ... missing.
- Replace missing lifebuoy(s) and report.
- Lifebuoy(s) at ... replaced.
- Lifebuoy(s) not available.
- Lifebuoy(s) at ... damaged.
- Replace damaged lifebuoy(s) and report.
- Lifebuoy(s) at ... replaced.
- When was last man-overboard drill?
- Last man-overboard drill was on....

-Person-overboard activities

- "Man overboard!"
- Man overboard on port side / starboard side / astern.
- Drop lifebuoy(s) and report.
- Lifebuoy(s) dropped (on port side / starboard side / astern).
- Sound "man-overboard" alarm.
- Hoist flag signal "Oscar" and report.
- Flag signal "Oscar" hoisted.
- Hard-a-port / hard-a-starboard the wheel.
- Is person in water / lifebuoy located?
- Yes, person in water / lifebuoy located.
- Report direction and distance of person in water / lifebuoy.
- Direction at ... points port side / starboard side / ... degrees, distance ... meters.
- Maintain visual contact to person in water / lifebuoy.
- No, person in water / lifebuoy not located (yet).
- Look out for person in water / lifebuoy and report.
- Passenger / crew member missing (for ... hours / since ... UTC) - search in vessel no result.
- Stop engine(s).
- Transmit alarm signal - PAN-PAN / distress alert - MAYDAY to radio coast station
- / Rescue Co-ordination Centre / vessels in vicinity and report.
- Alarm signal - PAN-PAN / distress alert - MAYDAY transmitted.
- Alarm signal - PAN-PAN / distress alert - MAYDAY acknowledged from....
- Return maneuver! Port / starboard, steer... degrees.
- Report position.
- Position....
- Report traffic situation.
- No vessel in vicinity.
- Following vessel(s) in vicinity....
- Report weather situation.
- Sea state....
- Winds Beaufort force ... from....

- Visibility ... meters.
- Current ... knots to ... degrees.
- Have man-overboard stations manned and report.
- Man-overboard stations manned.
- Have lookouts at ... manned and report.
- Lookouts at ... manned.
- Stand by for recovering from shipboard and report.
- Standing by for recovering from shipboard.
- Stand by boat / motor lifeboat no. ... For let go and report.
- Rescue boat / motor lifeboat no. ... standing by for let go

2.2.3. Cargo and Cargo Handling

2.2.3.1. Cargo Handling Procedure

➤ Loading and Unloading

-Loading capacities and quantities

- What is deadweight of vessel?
- Deadweight ... tonnes.
- What is hold capacity of vessel?
- Hold capacity ... cubic meters.
- What is bale capacity of vessel?
- Bale capacity ... cubic meters.
- What is grain capacity of vessel?
- Grain capacity ... cubic meters.

➤ Handling Dangerous Goods

-Briefing on nature of dangerous goods

- What is IMO-Class of these goods?
- IMO-Class of these goods:
- This package contains IMO - Class ... goods.
- These goods/liquids/substances are flammable/oxidizing/poisonous - handle with caution.
- These goods emit flammable gases in contact with water - keep dry.
- These goods are liable to spontaneous heating and combustion.
- Do not touch....

-Instructions on compatibility and stowage

- Observe IMDG-Code when loading/stowing.

- Check proper segregation of goods.
- Check correct technical names in documents.
- Check correct marks/labels/placards.
- Check compatibility of IMO-Class ... goods.
- Stow flammable goods away from engine room bulkhead/....
- Stow IMO-Class ... goods away from living quarters.
- Stow IMO-Class ... goods away from....
- Stow IMO-Class ... goods separated (by one hold) from IMO-Class ... goods.
- Stow infectious substances separated by one hold/compartiment from foodstuffs.
- Stow IMO-Class ... goods under deck.
- Stow IMO-Class ... goods on deck.

-Reporting incidents

- Sling(s) with carboys/bottles/drums/ ... of IMO-Class ... goods dropped on deck.
- Liquid/powder/gas escaping.
- Several drums/barrels/tanks/ ... leaking.
- Several drums/tanks/ ... deformed.
- Leaking substances/oil/liquid/ ...of IMO - Class ... escaped into sea (inform pollution control).
- Leaking substances/oil/liquid/ ...of IMO - Class ... escaped into harbor basin (inform pollution control).
- Temperature in locker/container/ ... with IMO-Class ... goods increasing (rapidly).
- Orange/red/white/ ... smoke developing among IMO-Class ... goods (on deck).

➤ Handling Liquid Goods, Bunkers and Ballast Pollution Prevention

- Preparing safety measures
- Plug scuppers and report.
- Scuppers plugged.
- Plug saves - all's / drip - trays and report.
- Save - all's / drip - trays plugged.
- Close sea - valves / discharges and report.
- Sea - valves / discharges closed.
- Stand by absorbent material/sand and report.
- Absorbent material/sand standing by.
- Stand by spill control gear and report.

-Operating pumping equipment

- What is (maximum) loading rate / discharge rate?
- (Maximum) loading rate / discharge rate: ... tonnes per hour.
- How many tones of ... oil / ... can you take?
- We can take ... tonnes of ... oil /....
- Is COW - system / inert gas system operational?
- Yes, COW - system / inert gas system operational.
- No, COW - system / inert gas system not operational (yet).
- COW - system / inert gas operational in ... minutes.
- When will crude oil washing start?
- Crude oil washing will start in ... minutes.
- How many pumps?
- Number of pumps:

➤ Preparing for Sea

- Close and secure hatch covers for sea and report
- Hatch covers closed and secured.
- Lash and secure goods for sea and report.
- Goods lashed and secured.
- All cars/wagons/ ... lashed and secured.
- Lower and secure derricks/cranes for sea and report.
- Derricks/cranes lowered and secured.
- Check lashings and securing's and report.
- Lashings and securing's fast.
- Check seaworthiness of holds and report
- Holds seaworthy.
- How many tonnes/cubic meters loaded?
- ... tonnes/cubic meters/ ... loaded.
- How much ballast can vessel take (down to her marks)?
- Vessel can take ... tonnes of ballast.
- Check trim.
- Fill forepeak to decrease stern trim.
- Fill double-bottom tank(s).
- Pump fuel from ... tank to ... tank to bring vessel upright.

2.2.3.2. Cargo Care

➤ **Operating shipboard equipment for cargo care**

- Is equipment for cargo care operational?
- Yes, equipment for cargo care operational.
- No, (*equipment*) not operational (yet).
- ... (*Equipment*) operational in ... minutes.
- What is air change rate of hold ventilators?
- Air change rate of hold ventilators ... -fold.
- Are temperature recorders/humidity recorders in hold(s) operational?
- Yes, temperature recorders/humidity recorders in hold(s) operational.
- No, temperature recorders/humidity recorders in hold(s) not operational (yet).
- Temperature recorders/humidity recorders in hold(s) operational in ... minutes.

➤ **Taking Measures for Cargo Care**

-Carrying out inspections

- Holds must be inspected by surveyor before loading.
- Check reefer holds for proper loading preparation and report.
- Reefer holds must be inspected by sanitary service before loading.
- Reefer holds must be pre-cooled for survey.
- Reefer holds ready for loading.
- Are holds clean (dry and free of smell)?
- Yes, holds clean (dry and free of smell).
- No, holds not clean (dry and free of smell) (yet).
- Holds clean (dry and free of smell) in ... minutes/hours.
- Check operation of hold ventilators and report

-Describing damage to the cargo

- (*Cargo*) in bad condition.
- Packages of ... (*cargo*) wet.
- Packages of ... (*cargo*) damp/moldy.
- Packages of ... (*cargo*) marked by fresh water/sea water.
- Metal of ... (*cargo*) rusty.
- Bands of ... (*cargo*) broken/missing/rutty.
- Crates/cases with ... (*cargo*) renailed.
- Boards of crates/cases with ... (*cargo*) loose.
- Marks/labels on ... (*cargo*) unclear/illegible/false.
- Contents of drums/barrels/ ... unknown.

- Weight of ... (*cargo*) *unknown*.
- ... Container damaged before loading.
- ... Container damaged in loading.
- ... Container damaged by shifting on board.
- ... Container damaged by heavy seas.
- ... Container washed overboard (inform on radio).
- Container open (and contents (partly) missing).

2.2.4. Passenger Care

2.2.4.1. Briefing/instruction

➤ **Conduct of Passengers Aboard**

-General information on conduct of passengers on board

Ladies and Gentlemen. This is Captain ...speaking. I have pleasure in informing you that all safety equipment is in full working order. The bow/stern doors are closed and secured. The ship is in all respects ready for sea. Please listen carefully to the safety instructions which follow. In the unlikely event of an emergency, please obey the orders given on the public address system.

Passengers are requested to read all notes and leaflets concerning safety regulations.

All regulations concerning the ship's routine have to be obeyed.

-Briefing on prohibited areas, decks, spaces in the ship

Safety regulations do not permit passengers to enter the following spaces:

- navigating bridge
- engine room
- maneuvering areas at the front and back end of the ship
- cargo rooms and compartments
- service rooms
- all areas and spaces marked "Crew only"
- all closed, sealed and/or roped off areas, spaces and rooms
- Car decks when the ship is at sea.

➤ **Briefing on Safety Regulations/Preventive Measures/Communications**

International regulations require all passengers to be assembled in a drill which has to take place within 24 hours of leaving port.

- A drill will be held
- To familiarize passengers with their assembly stations
- To familiarize passengers with their life-saving equipment
- To familiarize passengers with emergency procedures
- All passengers must attend this drill.

-General emergency alarm

In case of emergency seven short blasts and one long blast will be given with the ship's whistle and the alarm system. Remain calm when you hear the general emergency alarm. Passengers will be taught how to act and behave in cases of emergency

-Preventing/reporting fire

- Always remember that fire is the greatest hazard aboard ship.
- Always act immediately if you detect fire, smell or smoke.
- Always inform somebody of the crew if you detect fire, smell or smoke.
- Be careful to extinguish cigarettes completely.

-P.A. announcements on emergencies

2.2.4.2. Evacuation and Boat Drill

-Allocating/directing to assembly stations, describing how to escape

When the general emergency alarm is sounded which consists of seven short blasts and one long blast, all passengers have to go to their assembly station. Take your lifejackets and blankets with you. Lifejackets are stored in your cabins under your beds and at your assembly stations. You are encouraged to try on your lifejacket.

All passengers must put on warm clothing long trousers, long-sleeved shirts/jackets strong shoes and head covering.

All passengers with their lifejackets and blankets are requested to go to their assembly stations/the lounge/ the ... immediately.

- From your assembly stations you will be escorted to your lifeboats/life rafts.
- All passengers are requested to carefully study the safety instructions behind their cabin doors.

-Briefing on how to dress and what to take to assembly stations

- Take your lifejacket and a blanket.

- You will find your lifejacket under your bed.
- Put on warm clothing, long-sleeved shirts, strong shoes and head covering whatever the weather.
- No high-heeled shoes.
- Do not forget personal documents, your spectacles and medicine if necessary.
- Do not return to your cabin to collect your property.

-Performing roll call

- At your assembly station one of the officers/crew will perform a roll call.
- The officer/crew will say "This is a roll call", and he will call out the passengers individually by their names.
- When your name is called out, please answer loudly "Here".
- If one of your cabin mates is not able to attend the roll call, please inform the officer/crew immediately.

2.2.4.3. Attending to passengers in an emergency

-Informing on present situation

- The ship was abandoned in position.... due to fire/grounding/collision/flooding/ heavy list/serious damage/....
- Keep calm. There is no reason to panic. The officers/lifeboat men know exactly what to do.
- There are enough life-saving appliances for everyone on board.
- Rescue Co-ordination Centre/ships in the vicinity have already been informed of our situation.
- Ships/helicopters/airplanes are coming to our rescue.
- Ships/helicopters/airplanes will reach us within hours.
- We have radio contact with rescue craft.
- There are enough provisions and drinking water for 48 hours.
- You obtain medicine for seasickness from the life boatman

-Escorting helpless passengers

- Persons are missing.
- Search all cabins/WC/showers for missing persons.
- Assist those who need help.
- Help children, elderly, disabled, injured or sick persons with lifejackets.
- Give assistance when entering lifeboats/life rafts.
- We require warm clothing and blankets for the children/elderly/disabled/injured/sick.

-
- We require a stretcher for the disabled/injured/sick.
 - All persons please move closer. The elderly/disabled/injured/sick need room to lie down.
 - All persons, please, be quiet. The children/sick need rest.

APPLICATION ACTIVITY

Steps Of Process	Suggestions
<ul style="list-style-type: none"> ➤ You should communicate with VTS in all situations.(e.g. Distress, Urgency, Safety and Security)for developing external communication. ➤ You should communicate with other ships .(e.g. Distress, Urgency, Safety and Security) for developing external communication. ➤ You should communicate with coast stations .(e.g. Distress, Urgency, Safety and Security) for developing external communication. ➤ You should communicate with Ship’s personnel in all situations.(e.g. Distress, Urgency, Safety and Security)for developing internal communication. ➤ You should communicate with Officers in all situations.(e.g. Distress, Urgency, Safety and Security)for developing internal communication. 	<ul style="list-style-type: none"> ➤ During application you should be careful for pronouncing about SMCP mistakes ➤ Always be careful about safety of work on ships.

CHECKLIST

If you have behaviors listed below, evaluate yourself putting (X) in “Yes” box for your earned skills within the scope of this activity otherwise put (X) in “No” box.

Evaluation Criteria	Yes	No
➤ Do you know using SMCP in all conditions?		
➤ Do you know how to establish sentences in all situations?		
➤ Do you know how to spell sentences in all situations?		
➤ Do you know how to read sentences in all situations?		
➤ Do you know how to write sentences in all situations?		
➤ Do you know how to understand sentences in all situations?		
➤ Do you know which sentence and where we use for SMCP in all situations?		

EVALUATION

Please review your” No” answers in the form at the end of the evaluation. If you do not find yourself enough, repeat learning activity. If you give all your answers "Yes" to all questions, pass to the "Measuring and Evaluation".

MEASURING AND EVALUATION

I. Choose the correct answer.

1. Which expression points out a “position” phrase?
 - A) You are entering
 - B) You are sailing
 - C) Mayday
 - D) Where is

2. Which expression points out a “course” phrase?
 - A) This is a course
 - B) Do not enter
 - C) Course to degrees.
 - D) Course failed

3. Which expression points out a “anchoring” phrase.
 - A) It’s harbor.
 - B) Anchoring prohibited.
 - C) You can go
 - D) Fire

4. Which expression points out a “tug assistance” phrase
 - A) Where is the boat?
 - B) Turn left
 - C) Ship overload
 - D) I require tug(s)

5. Which expression points out a “Propulsion system” phrase
 - A) Is engine diesel or turbine?
 - B) Motor!
 - C) Load the cargo
 - D) Is radar operational?

EVALUATION

Please compare the answers with the answer key. If you have wrong answers, you need to review the Learning Activity. If you give right answers to all questions, pass to the general revision.

GENERAL REVISION

1. Complete these phrases.

- a. In shore-to-ship and ship-to-shore communication or radio communication in general, the following eight Message Markers may be used: _____
- b. (Responses) When the answer to a question is in the affirmative, say: _____
- c. (Corrections) When a mistake is made in a message, say: _____
- d. (Repetition) When a message is not properly heard, say: _____
- e. Distress, urgency and safety signals are _____

2. Find these words in the puzzle.

BERTH-BLAST-CASUALTY-DESTINATION-FAIRWAY-FLOODING-OVERFLOW-PROCEED-TRANSIT-WRECK

B	A	D	B	L	A	S	T	U	R	H	C	W	X	O
E	C	E	V	U	I	C	A	S	U	A	L	T	Y	V
R	F	S	P	G	I	Q	T	Y	U	C	Z	X	M	E
T	A	T	Q	Q	F	L	O	O	D	I	N	G	S	R
H	I	I	T	S	M	X	U	H	E	T	Y	P	O	F
Q	R	N	P	P	R	O	C	E	E	D	Q	W	X	L
A	W	A	I	T	D	R	W	W	R	H	Y	E	Z	O
Z	A	T	U	T	R	A	N	S	I	T	G	D	C	W
C	Y	I	Y	L	F	T	S	D	F	G	H	I	T	Y
D	U	O	T	J	I	Y	Q	T	Y	U	J	I	O	P
T	H	N	R	X	J	U	W	R	E	C	K	E	D	U

EVALUATION

Please compare the answers with the answer key. If you have wrong answers, you need to review the Learning Activity.

ANSWER KEY

LEARNING ACTIVITY 1

1. Complete the sentences.

- a. **SMCP** has been compiled to assist in the greater safety of navigation and of the conduct of ship, to standardize the language used in communication for navigation at sea, in port-approaches, in waterways, harbors and on board vessels.
- b. **MAYDAY** means to announce a distress message.
- c. **PAN – PAN** means to announce an urgency message.
- d. **SÈCURITÈ** means to announce a safety message.
- e. **Times should be expressed** in the 24 hour notation indicating whether UTC, zone time or local time is being used.

2. Complete the charts.

Letter	Code	Letter	Code
A	<u>Alfa</u>	N	<u>November</u>
B	<u>Bravo</u>	O	<u>Oscar</u>
C	<u>Charlie</u>	P	<u>Papa</u>
D	<u>Delta</u>	Q	<u>Quebec</u>
E	<u>Echo</u>	R	<u>Romeo</u>
F	<u>Foxtrot</u>	S	<u>Sierra</u>
G	<u>Golf</u>	T	<u>Tango</u>
H	<u>Hotel</u>	U	<u>Uniform</u>
I	<u>India</u>	V	<u>Victor</u>
J	<u>Juliet</u>	W	<u>Whisky</u>
K	<u>Kilo</u>	X	<u>X-ray</u>
L	<u>Lima</u>	Y	<u>Yankee</u>
M	<u>Mike</u>	Z	<u>Zulu</u>

Figure	Code word
0	Nadazero
1	Unaone
2	Bissotwo
3	Terrathree
4	Kartefour
5	Pantafive
6	Soxisix
7	Setteseven
8	Oktoeight
9	Novenine
Full stop	Stop
Decimal point	Decimal

LEARNING ACTIVITY 2

1	A
2	C
3	B
4	D
5	A

GENERAL REVISION

1. Complete these phrases.

- a. In shore-to-ship and ship-to-shore communication or radio communication in general, the following eight Message Markers may be used: **Instruction, Advice, Warning, Information, Question, Answer, Request, Intention**
- b. (Responses) When the answer to a question is in the affirmative, say: **"Yes ..."** - followed by the appropriate phrase in full.
- c. (Corrections) When a mistake is made in a message, say: **"Mistake ..."** - followed by the word.
- d. (Repetition) When a message is not properly heard, say: **"Say again (please)."**
- e. Distress, urgency and safety signals are **MAYDAY- PAN PAN - SECURITE**

2. Find these words in the puzzle.

BERTH-BLAST-CASUALTY-DESTINATION-FAIRWAY-FLOODING-OVERFLOW-
PROCEED-TRANSIT-WRECK

B		D	B	L	A	S	T						O	
E		E				C	A	S	U	A	L	T	Y	V
R	F	S												E
T	A	T			F	L	O	O	D	I	N	G		R
H	I	I												F
	R	N		P	R	O	C	E	E	D				L
	W	A												O
	A	T		T	R	A	N	S	I	T				W
	Y	I												
		O												
		N					W	R	E	C	K			

REFERENCES

- www.imo.org